



Artira

Platform Stairlift for every type of stair

Index

Solutions for every need	3
Garaventa Lift, experts in accessibility	4
Artira, the innovative stairlift	5
Artira for every type of stair	6
Artira for every mobility need	8
Optimization for every location	9
We guarantee a minimal amount of space	10
Technical features	11

Solutions for every need

Garaventa Lift design highly customized solutions for the removal of architectural barriers combining the perfect integration into the location. For this reason, Garaventa Lift provides a free consultation with no commitment by accessibility experts.

Each platform stairlift is built on user's current and future needs ensuring a comfortably and safely use.

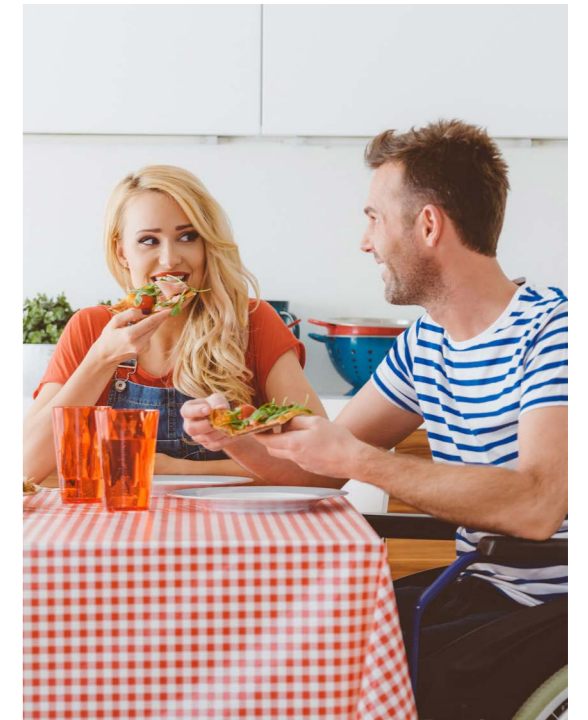

Garaventa Lift, experts in accessibility

Every day thousands of people with mobility difficulties are forced to overcome different type of barriers. Garaventa Lift takes these problems close to heart and this is the reason why, for decades, we constantly trying to offer to everybody solutions with sensitivity and professionalism.

Garaventa Lift in Italy and around the world



The Garaventa Lift Group designs, manufactures and installs around the world, stairlifts and home lifts to overcome every type of stair or differences in level both internal and external.



In Italy, Garaventa Lift is present with its factory and offices in Lainate (MI). In our offices and factory, we design and build your platform stairlift and through our dealer network we provide the maintenance service.

Garaventa Lift belongs to the most important trade associations:



Artira, the innovative platform stairlift

Artira is synonymous of innovation. The operation of the platform stairlift is totally electronic: a microchip, containing the characteristics of the tube guide design, it regulates the speed according to the guide design (bottom landing, straight, curve, upper landing), the opening and closing of the platform, the movement of the arms and the indication of any faults.

The Artira stairlift is mainly composed of three elements: the guides, the drive system and the conveyance.

Artira components

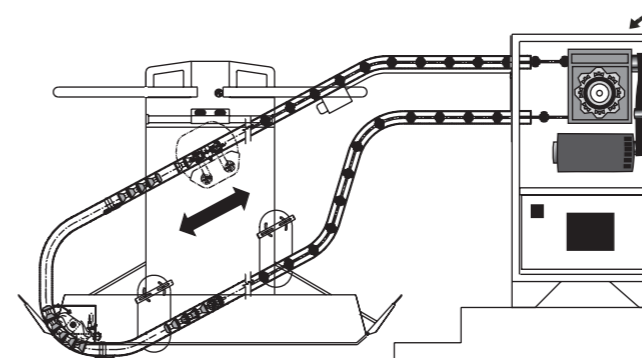

Guides

They consist of two tubes (diam.50 mm) that follow the staircase and contain the traction and support ropes.

The drive system

It consists of a geared motor (with different powers depending on the paths) and two separate ropes: traction and support, characterized by special balls and cones of self-lubricating material.

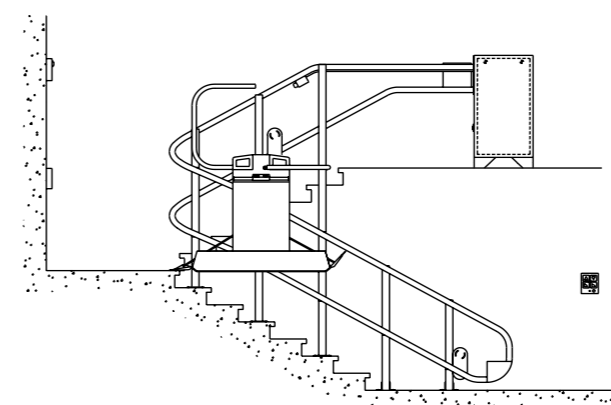

The conveyance

The conveyance is composed of a re-closable platform and, having no drive system on board, has very small dimensions.

The platform has different standard dimensions:

- 640 X 680 mm
- 700 X 750 mm
- 800 X 800 mm
- 800 X 900 mm
- 800 X 1050 mm
- 800 X 1220 mm

Artira's platforms can be customized after design verification to adapt to each stair. The vehicle folds up to reduce its size when it is not used

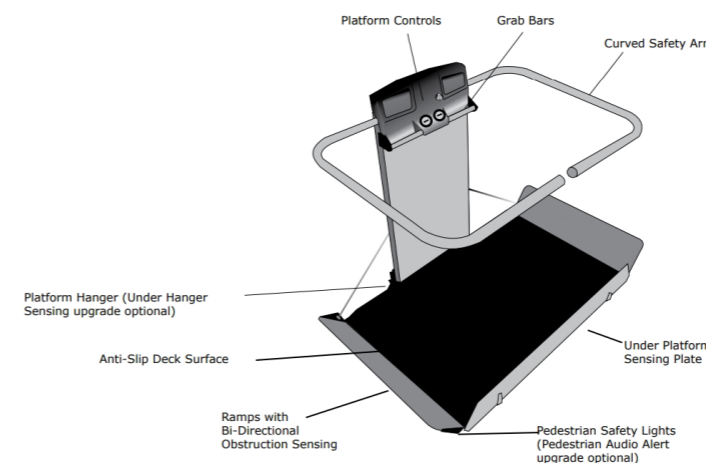

Would you like to know the configuration of Artira that best suits your needs?
Book a free consultation by calling us!

Artira for every type of stair

The motorized movements of the platform stairlift allow the user to overcome stairs and slopes of all kinds with ease and without effort, ensuring safety and total autonomy.

Artira is safe, easy to use and, above all, silent: it is ideal for both single-family and condominiums or buildings with multiple users.

Artira is the perfect solution for straight, curved and differently inclined stairs.

It can be installed to indoor and outdoor stairs: the special hot-dip galvanizing treatment gives greater resistance to the elements and to different climatic conditions.

The absence of the motor on board and the compact design, make the encumbrance of Artira minimal.



Curved stairs



Narrow stairs



Negative bends

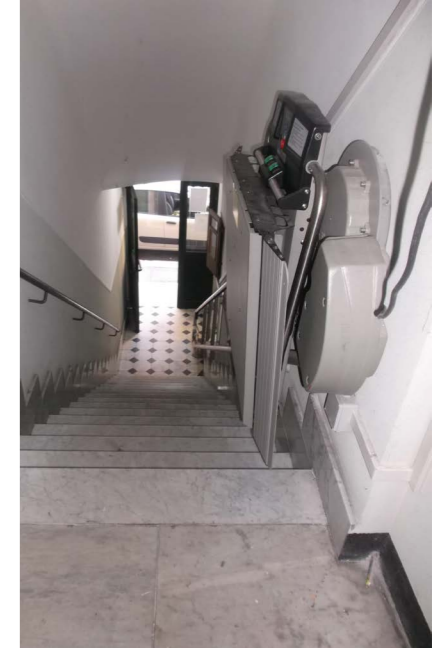

Steep stairs



Spiral stairs



Outdoor stairs



Multi ramps stairs



Long pathways



Condominium entrances

Artira for every mobility need

Artira is able to meet the mobility needs of every person. For this reason it is the platform stairlift that is better suited to those contexts in which there are users of different mobility needs such as condominiums, public buildings and retail applications.

Folding seat and customizable dimensions



The Artira stairlift can be customised to the dimensions of the platform (details on page 5).

Artira can be equipped with a comfortable folding seat allowing its use even to non wheelchair users.

With a single system it is possible to allow users with different needs to overcome the stairs independently.

Optimization for every location

It is important that your platform stairlift fits perfectly into your home, condominium or store. For this reason, Garaventa Lift studies, designs and builds every platform stairlift in detail proposing solutions to safeguard the space and integrate perfectly into the location.

Platform shape

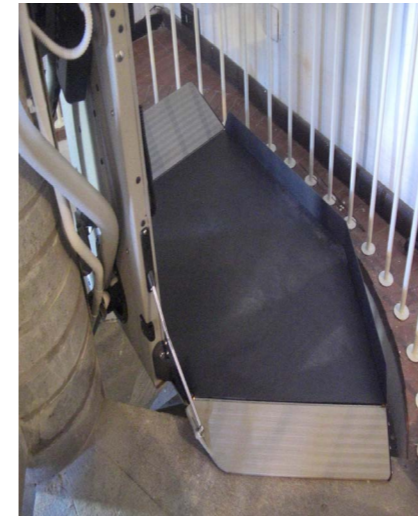

Platform with customized platform

Colors



Example of coloring of Artira

Space-saving solution

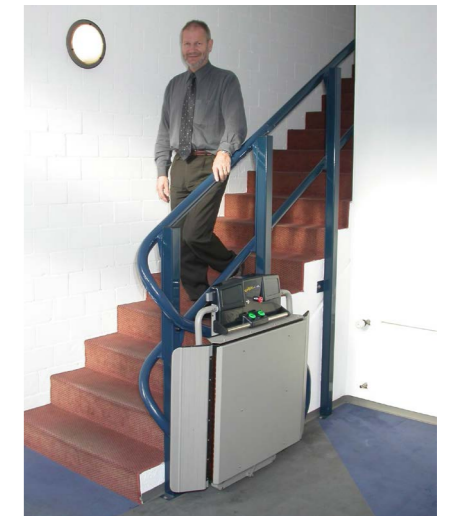

Artira closed at the start

Drive system placement



Artira for people on a wheelchair



Artira for people on a scooter



Artira with folding seat

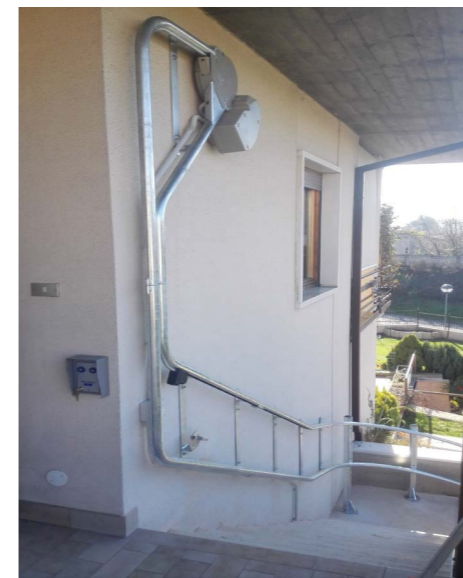

Ceiling mounted "gooseneck" drive system.



90° drive in the eye of the stair.

The Artira platform lift adapts to any space and to the narrowest and most irregular stairs.

The secret is the absence of the drive system on board the platform that guarantees the minimum encumbrance onto the staircase.

The drive unit can be placed into a position to leave the passage clear along the staircase and on landings.

Following the design verification it is possible to identify the most suitable drive unit position.

We guarantee a minimal amount of space

Fixing systems

With Artira you will not occupy any other space except that which is strictly necessary to overcome the stairs independently and freely. The possibility of closing the platform base when the platform stairlift is not used and the flexibility of the fixing systems make it possible not to hinder the normal passage along the staircase.



Wall fixing



Step fixing

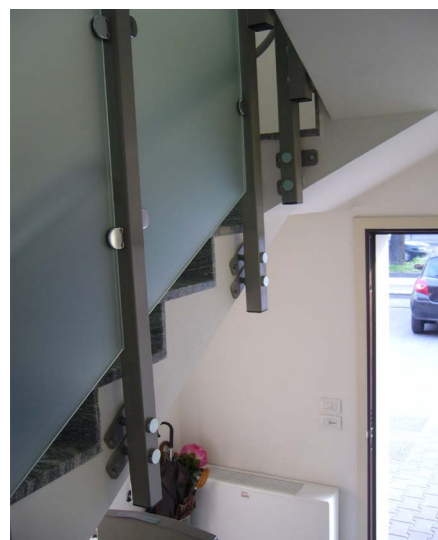

Fixing on stair stringer



Fixing on the stringer

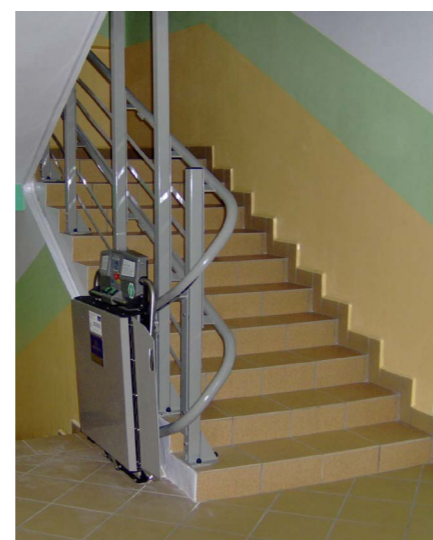

Fixing into the stairwell

Other fixing systems

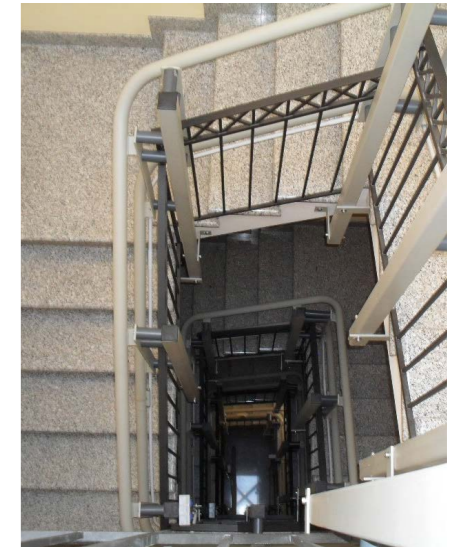

Technical features

General characteristics

Rated Load	250 Kg / 1 passenger
Rail System	Two 51mm (2") O.D. steel tubes spaced 600mm (23 5/8") apart vertically
Max Speed:	0,10 / 0,15 m/s . Speed reduction near stops and curves
Power Requirements:	single-phase 230v - 50Hz
Controls and Directional buttons	on board and landing call stations.

Optional

- Intermediate stops
- Side load
- Audio-visual signal
- Attendant Remote Control
- Folding seat
- Key switch

Would you like to know the configuration of Artira that best suits your needs?

[Contact us for free consultation](#)



Garaventa Lift Srl

Via Pogliano 22-26 · 20045 Lainate (MI) · Italy
E info@garaventalift.it · **I** www.garaventalift.it

Tech Support

T +39 02 49 63 39 95 · **E** TSG.Italy@garaventalift.it

Authorized Garaventa Lift Representative